

## *Introduction*

Fencing - just mentioning the word brings about a wild consortium of emotional thoughts for most livestock producers. There are no “right” fence styles or types for all operations or situations; it is a matter of preference. Economic considerations must be taken into account when building, replacing or mending fence.

Before you set the first corner post, take time to cover a few non-fence building issues. Contact your local zoning office and find out setback requirements. *You may be subject to new regulations, even if you are replacing an older existing fence.* Also, there may be local requirements on the type or style of fencing. The task of fencing is usually “pleasant” enough the first time; you don’t want to have to do it twice.

There are also legal issues that focus on fencing. State or local laws might be found in the law library at the local courthouse. Check this out before you tear out that old boundary fence. It is a good idea to talk over your fencing plans with the neighbor whose property will be next to the fence.

Many livestock producers shy away from electric fences in favor of the five-strand, barbed wire or woven wire fence with metal T-posts. Today, high tensile electric fences are generally more economical fences because they tend to be less expensive and are easier to install and maintain.

The materials cost vary depending on the type of fence, how it is constructed and the site on which it is located. Factors to consider are corner posts, terrain and the type of animals to keep in or fence out. High tensile is the cheapest part of an electric fence. Posts (either wood, fiberglass or metal), gates, energizers and insulators increase fencing costs the most. An example is given later in the lesson. The best way to compare costs of different fencing systems is to do so over a constant distance (ie. one mile).

There are many good publications and materials on electric fencing systems. Rather than reinventing the wheel we have included information already in publication. David W. Pratt, Farm Advisor with the University of California Cooperative Extension Service, wrote the following materials for this lesson. We have modified some of D. Pratt’s papers for our local conditions.

- A. Electric Fence Design**
- B. Training Livestock to Electric Fences**
- C. Quick Guide to Troubleshooting Problems with Electric Fences**
- D. Working With High Tensile Fence Wire**
- E. Fences That Work: Temporary Electric Fence Materials Evaluation**

## ***A. ELECTRIC FENCE DESIGN***

The effectiveness of any electric fence, whether it's a one wire fence subdividing a pasture or a 9 wire fence protecting stock from predators, depends on the ability of the fence to deliver an unpleasant shock to animals that touch it. The ability of a fence to deliver that shock depends on three things:

1. **The energizer**
2. **Grounding**
3. **The fence design**

The ideal fence is inexpensive to build and effectively control animals. There is no single design that meets these criteria for every application. The effectiveness of any design depends on the type of animal that must be controlled, the materials used in construction and site characteristics (e.g. soil moisture, terrain, etc.)

### ***HOW MANY JOULES DO YOU NEED?***

The number of joules (unit of energy measurement) needed depends on the length of the fence, the number of electrified wires and severity of conditions. Joule recommendations of chargers are dependent on length of fence to charge and soil conditions on which you plan to erect a fence. If you wish to install an electric fence that is one mile in perimeter, and you are charging four strands on the fence, your total fence length is four miles. Check with your fencing supplier to determine the appropriate charger for your fencing needs. Under severe conditions (wire passing through heavy vegetation) higher joule ratings may be required.

### ***PULSES***

Energizers differ in the size and duration of the pulses of electrons they send into the fence line. A good energizer has an intense pulse lasting for 0.0003 seconds. These short pulses eliminate the risk of fire (the pulse is so short that no heat builds up in the wire). Poorer quality energizers have pulse lengths of 0.003 to 0.3 seconds. This longer "on" time may allow sparks to arc and heat to build up. This can cause fires. This will also shorten the life of polywire. (These long pulses will cause polywire to melt where it comes in contact with grass.)

### ***HIGH IMPEDANCE VS. LOW IMPEDANCE***

Impedance means leakage. Generally speaking, high voltage energizers with long pulses are high impedance energizers. The current leaks readily. Low impedance energizers resist leakage.

### ***POWER SOURCE***

If mainline power is available and dependable, 110 or 220 volt AC (plug it in the wall socket) energizers are usually most practical for permanent fences. Will they raise your electricity bill? Well, depending on the size of the unit, they typically draw 2 to 25 watts a day. The operational cost of an energizer drawing 17 watts a day would be about \$1.50/month (assuming an electrical rate of \$0.12/kilowatt hour).

AC chargers have several advantages over DC (battery powered) energizers:

- **They require no battery maintenance**
- **They usually have higher joule ratings *per dollar spent***
- **They are generally placed in or close to buildings (reducing the risk of vandalism)**

Where mainline power is unavailable or unreliable, battery powered energizers are a practical alternative. Dry cell batteries can power some portable DC energizers. *Beware - manufacturer estimates of battery life are usually optimistic. In permanent installations solar is expensive but in the long run a viable alternative to constantly changing batteries.*

For longer or permanent fences or for short temporary fences passing through tall wet grass (high leakage), larger energizers powered by 12-volt rechargeable wet cell batteries should be used. Deep cycle batteries are the batteries of choice. They can be completely discharged and recharged repeatedly. Conventional car batteries can be used but they are not designed to be totally discharged. They will only recharge up to about 60 to 75% of their original capacity.

### ***SIX TIPS FOR BUYING AN ENERGIZER***

1. **Check the joule rating.** Remember: you double the shock by doubling the joules.
2. **Buy an energizer with the capacity to do the job.**
3. **Check the cost per joule.** One way to compare the value of energizers is to calculate the cost per joule. Generally speaking, the lower the cost per joule the better the value.
4. **Buy a low impedance energizer** with pulses of 0.0003 seconds or less.
5. **Look for solid state circuitry with modular service boards.** It makes repair much faster and simpler.
6. **Check the guarantee.** They vary in length and items covered. Some cover lightning damage.

### ***ENERGIZER DON'TS***

- **Don't buy on price alone.** The energizer with the cheapest price generally turns out to be the most expensive.
- **Don't skimp on the joule rating.** Buying more joule capacity than currently needed will give you the flexibility to charge fences built in the future without having to buy an additional unit.
- **Don't forget to ground the system.** Even the largest energizer in the world is useless without effective grounding.

### ***GROUNDING ELECTRIC FENCES***

Poor grounding is the leading cause of electric fence problems. Eighty percent of electric fence problems can be traced to faulty grounding systems.

## ***EFFECTIVE GROUNDING COMPLETES THE CIRCUIT***

For an animal to receive a shock it must complete a circuit. The circuit can be either from the energizer through a "live" wire through the animal, through the soil, and through ground rods back to the energizer (figure 1A), or from the energizer, through a live wire, through the animal, through a ground wire back to the energizer (figure 1B).

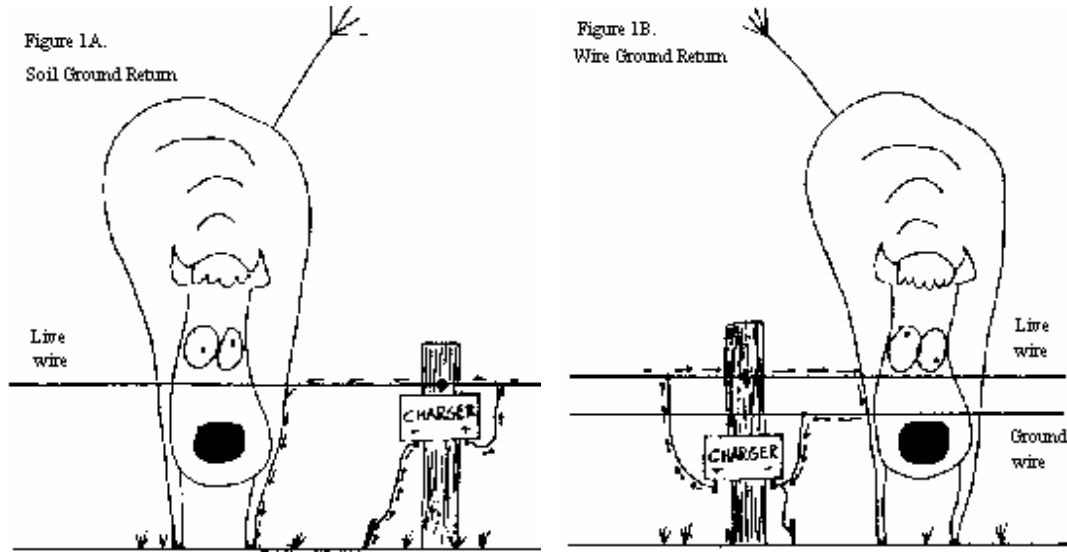

Moist soil is a good conductor of electricity. However, when soil moisture is depleted (or not effective when frozen), animals will not be shocked by electric fences unless ground wires are included on the fence.

## ***DESIGNING AN EFFECTIVE GROUNDING SYSTEM***

The grounding system for an electric fence is a little like a radio antenna. With a radio, the bigger the antenna, the better the reception. Likewise, your electric fence energizer requires a large grounding system to collect enough electrons from the soil to complete a powerful circuit.

A minimum of three ground rods should be used for each (most) energizer(s). *Many 1 joule units only need 1 rod.* Five-eighths inch diameter galvanized steel rods or 3/4" galvanized pipe make the best ground rods (**DO NOT USE COPPER**). They should be at least 6 feet long and driven 5-1/2 feet into the soil. They should be spaced at least ten feet apart. More ground rods may be needed in dry areas. If your fence includes ground wires, it is advisable to install additional ground rods connected to the ground wire at 1500 foot intervals along the fence line (3000 foot intervals are adequate where soil is moist year round). Energizers should be connected to ground rods with 12-1/2 gauge wire attached with ground rod clamps (below). The connecting wire should be insulated so that it does not come in direct contact with the soil (i.e. 12-1/2 gauge direct burial cable is ideal). Use one continuous wire to connect all ground rods.

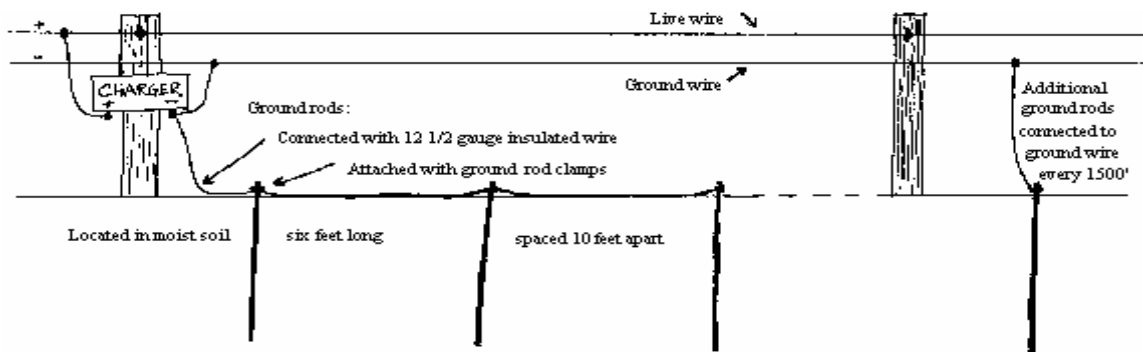

### Lightning Protection:

In addition to setting up the power system to the fence, one should consider and plan for a way to handle a lightning strike. If at all possible, the energizer should be unplugged during an electrical storm. Additionally, a lightning diverter (as good as or better than your grounding system) should be incorporated into your fencing construction. Check with your local fence dealer for information on lightning diverters.

## ***B. TRAINING LIVESTOCK TO ELECTRIC FENCES***

Whether building permanent fences with high tensile steel wire or temporary electric fences with polywire, an electric fence is not finished until animals have been trained to respect it.

The training area should be a small area that has a perimeter of woven wire or boards with the electric fence installed inside the physical fence. Keeping the area small will reduce the time it takes animals to learn about the fence. It will also minimize the time needed to gather and return the animals that get out during training and reduce the time required to build and mend the training fence.

When you turn stock into the training area, keep an eye on the animals but leave them alone to discover the fence on their own. Livestock are curious and will investigate the fence. As they do, they'll get their first lesson. When first shocked, animals don't know how to react. Some back up, others bolt ahead.

When an animal investigates the fence a second time, it usually does so prepared to back up. Rarely do animals challenge a fence a third time. If an animal continues to challenge the fence, cull the animal.

Depending on the number of animals and the size of the paddock, training usually takes no more than one day. Some people put hay or grain across the fence to give stock some incentive to cross the fence. This can increase the speed of training but is usually unnecessary. Do not herd animals into the fence. Livestock need an escape route.

Sheep and especially goats are the most difficult class of livestock to train. Wool is an effective insulator, and therefore sheep are best trained just after shearing. Long haired cattle are also insulated by their coat from a fence charge. Some producers have trained sheep by attaching cut out aluminum cans containing a little molasses to the fence. When sheep come up to lick the can, they get shocked and learn quickly to respect the fence. Make sure the cans do not touch ground wires!

### ***LEARN FROM OTHERS' MISTAKES***

Controlling cattle or sheep with electric fences without first training the stock results in hours gathering stock and mending fences. If you take the time and effort to train stock, the fences are effective. ***If electric fences are to consistently hold livestock, training is essential! And remember animals need to be retrained each spring.***

## ***C. QUICK GUIDE TO TROUBLESHOOTING PROBLEMS WITH ELECTRIC FENCES***

<b>PROBLEM</b>	<b>PROBABLE CAUSES</b>
Energizer not on or no voltmeter reading across energizer output terminals when disconnected from fence.	<ul style="list-style-type: none"> <li>• Mainline power outage</li> <li>• Blown fuse on input circuit</li> <li>• Energizer switched off</li> <li>• Dry cell batteries dead, wet cell batteries discharged</li> <li>• Terminals corroded</li> <li>• Faulty energizer</li> </ul>
Energizer on but low voltmeter reading across energizer output terminals when disconnected from fence.  (classic signs of bad transformer)	<ul style="list-style-type: none"> <li>• Energizer switched to low setting</li> <li>• Weak batteries</li> <li>• Terminals corroded</li> </ul>
Energizer connected & operating but no voltmeter reading on fence.  (Dead short on fence)	<ul style="list-style-type: none"> <li>• Ground-return wire disconnected or broken</li> <li>• Feedwire terminals corroded, disconnected or broken</li> <li>• Broken live or ground-return wire on fence</li> </ul>
Low voltmeter readings at several places on fence.	<ul style="list-style-type: none"> <li>• Energizer on low setting</li> <li>• Energizer inadequate for length of fence</li> <li>• Weak batteries</li> <li>• Terminals corroded</li> <li>• Ground system inadequate</li> <li>• Soil dried out</li> </ul>
No voltmeter reading or low reading at one location on fence.	<ul style="list-style-type: none"> <li>• Broken wire</li> <li>• Dead short across wires</li> <li>• Broken or disconnected jumper wire</li> <li>• Disconnected or deteriorated ground rod</li> </ul>
Voltmeter reading on one wire higher than another or no reading from one live wire to ground-return wire or soil.	<ul style="list-style-type: none"> <li>• Broken or disconnected fence wire</li> <li>• Broken or disconnected jumper wire</li> <li>• Broken or disconnected ground wire</li> <li>• Broken or faulty insulator</li> <li>• Ground rod deteriorated</li> </ul>
Radio, TV or telephone interference.  (major short on fence)	<ul style="list-style-type: none"> <li>• Ground system inadequate</li> <li>• Antenna too close to fence</li> <li>• Fence parallel with antenna wires or telephone wires</li> </ul>

## ***D. WORKING WITH HIGH TENSILE FENCE WIRE***

High tensile fences are stronger and usually less expensive to build than traditional barbed and woven wire fences. Once you know a few simple wire-handling techniques you'll find they are also easier to build.

### ***SPINNING JENNY***

Make sure you have a straight jacket handy on the day you try to dispense a roll of high tensile wire without a spinning jenny. Spinning jenny is a device used to dispense wire smoothly without kinking or tangling. Don't try to work with high tensile wire without one.

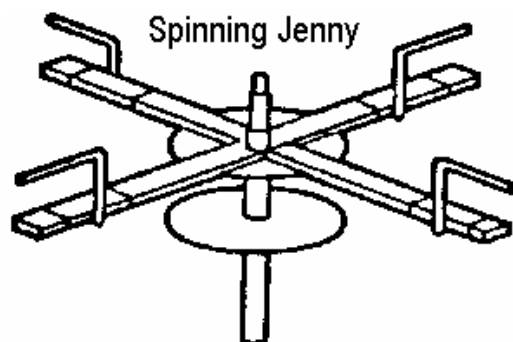

### ***START AT THE BEGINNING***

There is a lead end and a tail end to each spool of high tensile wire. Both ends may be visible on the spool. When wire is pulled off the spool, start with the lead end. The lead end on new rolls is identified with a tag. If you cut the wire, be sure to identify the lead end of the wire left on the spool.

### ***CUTTING WIRE***

You'll wear yourself out trying to cut high tensile wire with ordinary wire cutters (you'll also ruin your wire cutters). High tensile wire can be cut easily using high tensile wire cutters.

## ***TYING OFF***

High tensile wire can be "tied off" to brace posts using knots, nicopress sleeves or wire vises. It is easier to use a lower strength wire like 170 vs 200 to tie off.

### ***HALF HITCH KNOT***

High tensile wire may be stiff, but you'll find it relatively easy to make a simple half hitch knot to fasten the wire to brace posts (figures 2 & 3). The break strength half hitch is over 60% of the break strength of the wire (about 1100 pounds). To tie a half hitch:

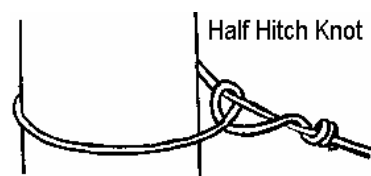

1. Pull about 3 feet of wire around the post.
2. Bring the end of the wire underneath and back over the line wire.
3. Bring the end down between the post and the wire that you just wrapped around the post.
4. Bring the tail under the wrap and over the line wire.
5. Make two tight wraps with the tail around the line wire.
6. Break or cut off the tail. Cutting leaves a rough surface.

Breaking wire will leave a smooth surface. To break off excess wire:

1. Put a 90° bend in the wire about 6" beyond the knot.

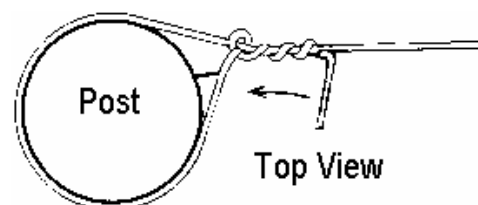



2. Grasp the wire just beyond the bend and crank it parallel to the fence line (back toward the post or splice). The wire will snap right off.

The faster you work, the easier the wire is to break. High tensile wire gets hot when worked slowly. When hot, the wire becomes more difficult to work and break off.

### ***NICOPRESS SLEEVES***

Nicopress sleeves can be crimped around high tensile wires with a nicopress tool (figure 4). The resulting connection has a break strength equal to that of the wire. To tie off wire with nicopress sleeves:

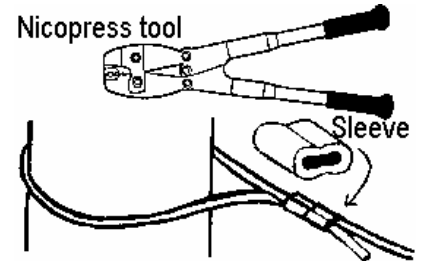

1. Thread two nicopress sleeves (or use one long sleeve) on to the wire and slide them back about 2 feet.
2. Feed the wire around the post. Thread the nicopress sleeves on the tail.
3. Slide the sleeves back to within a few inches of the post.
4. Crimp each sleeve with a nicopress tool.
5. Break or cut off the tail.

### ***WIRE VISE***

The wire vise has the same break strength as the fence wire. To install a wire vise:

1. Drill a 3/8" hole completely through the center of the brace post.
2. Feed each wire a few inches through the correct hole and into the wire vise.
3. Slide wire vise up the wire and into the hole in the post. When the wire is tensioned, the wire vise will become embedded in the post.
4. Break or cut off the surplus wire.

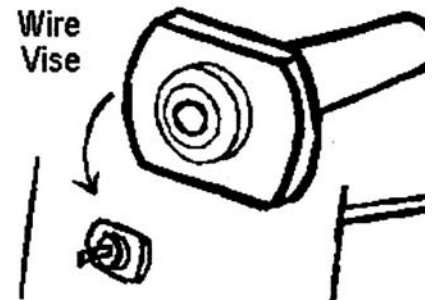

### ***INSULATORS & IN-LINE STRAINERS***

Both insulators and in-line strainers can be installed with two nicopress sleeves or by making at least 6 tight wraps with the tail around the line wire.

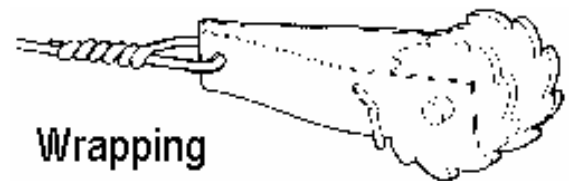

### ***SPLICING***

Wire can be spliced using a figure "8" knot, nicopress sleeves or a "wire link". Many prefer a gripple over a wire vise due to cost and effectiveness.

## ***FIGURE "8" KNOT***

The figure "8" is the most efficient knot for splicing high tensile wire (figure 7). It will maintain up to 76% of the strength of the wire. To tie a figure "8":

1. Overlap the wires to be spliced by about 4 feet.
2. In each piece make a small loop around the other wire. Leave yourself an 18" tail on each wire. The tails should be pointing in opposite directions.
3. Tension up the figure "8" so that the tails are touching.
4. Holding the figure "8" secure in the claws of a hammer, wrap the tail back onto the line wire with at least two wraps.
5. Break off the excess wire.

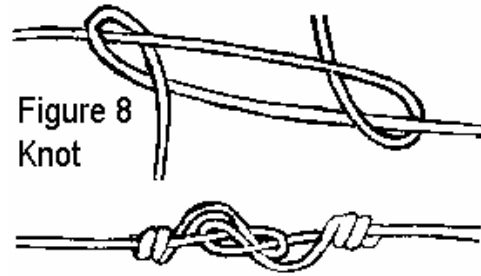

## ***NICOPRESS SLEEVES***

Splices can also be made using nicopress sleeves (figure 8). These splices have a break strength of 100% of the wire strength. To splice with nicopress sleeves:

1. Thread 3 sleeves (Or 1 long sleeve) on the first wire.
2. Thread the second wire through the other side of the sleeves.
3. Crimp the sleeves with a nicopress tool.
4. Cut or break off the tail.

## ***WIRE LINKS***

Splices can also be made with "wire links." Wire link splices maintain 100% of the strength of the wire. To splice with wire links:

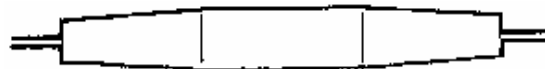

1. Insert both wires as you can in the ends of a wire link.
2. Tension the wire.

## ***E. FENCES THAT WORK: TEMPORARY ELECTRIC FENCE MATERIALS EVALUATION***

Temporary electric fences give livestock producers a powerful tool for pasture management. They consist of one or more flexible wires attached to insulated posts and charged with an energizer. The fences can be put up and taken down quickly.

### ***CUTTING THROUGH THE PROPAGANDA***

Some of the sales literature fencing companies provide is very informative and can help you design more effective electric fences.

Other sales literature can be confusing. Predictably every manufacturer claims their product to be superior to all others.

### ***TEMPORARY ELECTRIC FENCE TYPES***

There are three basic types of temporary electric fence products: polywire, polyrope and polytape. Polywire is a generic term referring to any of several brands of electroplastic twine. Polytape refers to electroplastic ribbon. Most polywires and polytapes are made up of stainless steel filaments interwoven with some polyethylene, polypropylene, or polyester fibers. The number of steel or aluminum strands varies from 3 to 9 depending on the product.

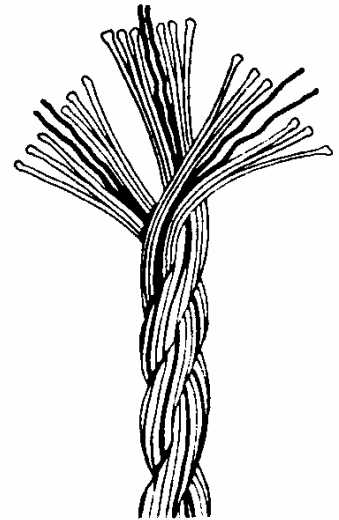

Maxishock cable is also marketed as a temporary portable fence wire. It consists of 7 strands of galvanized steel woven into a flexible cable.

Voltage dropped sharply in steel/polyethylene wires when over 1/2 mile from the energizer. Voltage in a fence with the aluminum/fiberglass material did not drop significantly when measured one mile from the energizer under field conditions. Aluminum is a better electrical conductor than steel. In addition, aluminum does not rust. However in thin filaments, it corrodes and becomes brittle – not a good choice

Maxishock cable was stronger and more conductive than the other products. It is also heavier, bulkier, and more cumbersome to dispense and rewind.

Polytape is more visible than polywire. However, it is also bulkier (a full reel of polywire builds more fence than the same reel full of polytape). Polytape is slightly more difficult to rewind, and it wears out more rapidly than polywire. Use polytape where visibility is important (horses); polytape comes in different widths depending on your use. Polyrope is a 3/8 inch braided rope with nine metal strands braided into the rope. Polyrope has some advantages over polytape since it is more visible and will not flutter in the wind. Use polywire for all other applications, especially multiple wire fences.

## ***NUMBER OF CONDUCTIVE STRANDS***

Predictably the six wire polywires were more conductive than the three strand materials. The nine strand polywires were more conductive than the 6 strand products. The nine strand polywires are stronger than the other products. However, the nine strand materials are bulkier and slightly more difficult to rewind. A full reel of nine-strand wire holds about 300 feet less wire than the same reel loaded with 6-strand material. The nine-strand polywire was also more expensive.

Under most applications six conductive steel filaments is plenty to do the job. While the nine-strand material is stronger, you don't need strength for an effective psychological barrier.

## ***COLOR***

If an animal doesn't see the wire they can't respect it. Visibility is critical, especially with poorly trained stock or where wildlife may challenge fences. Polywire comes in several colors and color combinations: white, black and white, orange, orange and black, yellow, and yellow and black. Orange and yellow wires look best on the farm supply store shelf but in the field white has them beat hands down. Against a lush green or dried yellow background, white is more visible. Time and time again untrained animals noticed white polywire from farther away than they noticed other colors. Buy white polywire unless you have to deal with snow for part of the year. In snow country use black and white or colored polywire. Black and white combo is best for all visibility.



## ***REELS***

A reel is essential. Rolling polywire back on the spool, on a stick or around your arm (the way you would roll an extension cord) simply won't work. You'll wind up kicking the dog, yelling at the kids and having nightmares about the money you've wasted and the mess you made.

Reels with steel cranks cost about \$10 more than reels with plastic cranks. Spend the money. A reel should be able to take a little abuse, after all this is for use on a farm, not a china shop.

## ***POSTS***

Metal "t" posts are the strongest, but most labor intensive to install and remove--a distinct disadvantage for temporary portable electric fences. The "t" posts also required insulators.

Fiberglass rods are easily tapped in with a hammer. Rod ends splintered when tapped. Fence suppliers sell a cap to place over the end of the rods to protect them when you tap them in. An expended shotgun shell works equally well and doesn't cost anything. Ultraviolet resistant coatings are now available on fence posts to reduce the chance of fiberglass splintering over time. It is recommended to store posts inside when not in use.

Polywire is attached to the rods using a wire clip or plastic insulators that slide on the rods. There are several types of wire clips. Some clips are difficult to adjust. The plastic insulators are most difficult to adjust in the field. Clips made for use with polytape (with an extra wide area to hold the wire) were easy to adjust and have a useful locking feature.



There are many kinds of tread-in posts. Lightweight fiberglass posts with one stationary and two adjustable clips did not go into the soil as easily as the two other tread-in post styles. Lightweight and heavyweight polyethylene tread-in posts with wire loops molded into the post and a steel spike at the bottom are also available. By stepping on a small platform at the base of the posts the spike tip went in easily and adequately secured the post. Under dry conditions they are difficult and sometimes impossible to install. The premolded loops provide plenty of flexibility for a variety of wire spacings.

For wetter ground it is difficult to beat the convenience of the tread-in posts with premolded loops (either lightweight or heavy duty). However they are more expensive than the fiberglass rods. Fiberglass rods make just as effective a fence but take a little longer to install. They are more versatile since they can be used under all conditions. Carry an empty shotgun shell case or fiberglass rod cap with you to place over the top of rods when you tap them in.

### **The following additional resources can be found in the Appendices**

#### **Appendix A**

Permanent Fencing Costs for Cattle and Sheep, M.V. Rudstrom, West Central Research and Outreach Center

#### **Appendix B**

A Stronger Brace... It's Less Expensive & Easier To Build, Too!

#### **Appendix C**

20 Common Mistakes to Avoid When Building a Good Electric Fence, Wayne Burlison, Range Management Consultant, Absarokee, Montana.

#### **Appendix D**

Fencing Vendors

#### **Appendix E**

Farm Fences - Planning, construction, and cost

### **Additional References**

**Mayer, Ralph, Extension Farm Management Specialist, Estimated costs for livestock fencing, Iowa State University Extension, FM 1855, Feb. 1999.**

**Selders, Arthur, McAninch, Jay; High-Tensile Wire Fencing, NRAES – 11, Northeast Regional Agricultural Engineering Service, Ithaca, NY, 1987.**

*Adapted by Ken Andries and Gary Anderson from Fencing Systems - Lesson 3, University of Minnesota Beef Education Series: Pasture Management Home Study Course - Robert F. Padula, Minnesota Extension Educator – Livestock Systems  
William A. Head, Sheep Scientist, West Central Research and Outreach Center*

Visit the UMCE Web Site at [www.umext.maine.edu](http://www.umext.maine.edu) and  
Maine Natural Resources Conservation Service Web Site at  
[www.me.nrcs.usda.gov](http://www.me.nrcs.usda.gov)

## ***APPENDIX A***

# ***Permanent Fencing Costs for Cattle and Sheep***

**M.V. Rudstrom**

**West Central Experiment Station**

Fencing represents a substantial investment in moving from confinement or continuous grazing systems to a rotational grazing system. The fencing can be either permanent fencing or temporary fencing. Generally, the permanent fencing surrounds the perimeter of the pastures or property while temporary fencing is used to divide pastures into smaller paddocks that are intensively grazed. Permanent fencing around the perimeter of pastures or property functions to keep animals in the pasture and deter predators from entering the pasture.

There are many different types of posts, wire, insulators, and energizers available for construction of permanent fencing. Keep in mind that where you save on materials you usually lose on annual repairs. That is, lower quality materials generally means higher annual repair costs. A well-constructed fence can have a life of 30 years with minimal annual repairs.

The costs presented are based on fence construction materials (retail price) used at the West Central Research and Outreach Center in Morris, MN. *(Costs change regularly and this page was quickly out of date, we have included it to give you a format for calculating fencing costs.)* Costs for your farm may vary depending on the materials that you use. The budgets are for materials and equipment only. Labor costs are not included. Generally labor cost will equal the material costs. The costs are based on a mile of fencing.

### ***Materials:***

**Line Posts:** 4" x 6" wood posts or fiberglass posts. They are placed 33 feet apart for sheep and 25 feet apart for cattle. For example, for sheep place wooden line posts every **99** feet with 2 fiberglass posts in between equally spaced. Wooden line posts can be spaced every 100 feet with fiberglass posts placed between them.

**Corner Posts:** 6" x 8" wood posts. Even if fiberglass posts are used, wooden corners are recommended for strength.

**High Tensile Wire:** 7 wires are used for sheep and 3 wires are used for cattle.

**Insulators:** All wires are attached to posts with insulators. Usually only 2 wires are hot or charged with the electrical impulses. Insulating all wires maintains the flexibility of making more wires hot if necessary.

**Energizer:** 12 joule fencer is used to energize the fence. This should be adequate to energize 24,000 feet (4.5 miles) of sheep fencing or 48,000 feet (9 miles) of cattle fencing.

**Miscellaneous Items:** Gates, springs and strainers, jump wires

**Equipment:** Post digger for corner posts and wooden line posts, hammer, high tensile wire cutters.

### Permanent Fencing for Beef or Dairy Cattle

	<b>Cost per Unit</b>	<b>Number per Mile</b>	<b>Cost per Mile</b>
Wood Line Posts	\$4.50	211	\$949.50
Fiberglass Line Posts	\$1.00	211	\$211.00
Corner Posts	\$5.50	10	\$55.00
Insulators for Wood Line Posts	\$0.15	1055	\$158.25
Fiberglass Post Clips	\$0.10	1055	\$105.50
High Tensile Wire	\$0.01 per foot	26,400	\$264.00
Tension Springs	\$5.00	30	\$150.00
Tension Strainers	\$3.50	5	\$17.50
Jump Wires	\$3.00	5	\$15.00
Gate	\$75.00	1	\$75.00
Energizer	\$350.00	0.11	\$38.50
Total Cost - Wood Line Posts			\$1722.75
Total Cost - Fiberglass Line Posts			\$931.00

One mile equals 5,280 feet

### Permanent Fencing for Sheep

	<b>Cost per Unit</b>	<b>Number per Mile</b>	<b>Cost per Mile</b>
Wood Line Posts	\$4.50	160	\$720.00
Fiberglass Line Posts	\$1.00	160	\$160.00
Corner Posts	\$5.50	10	\$55.00
Insulators for Wood Line Posts	\$0.15	1120	\$168.00
Fiberglass Post Clips	\$0.10	1120	\$112.00
High Tensile Wire	\$0.01 per foot	37000	\$370.00
Tension Springs	\$5.00	42	\$210.00
Tension Strainers	\$3.50	7	\$24.50
Jump Wires	\$3.00	5	\$15.00
Gate	\$75.00	1	\$75.00
Energizer	\$350.00	.22	\$77.00
Total Cost - Wood Line Posts			\$1714.50
Total Cost - Fiberglass Line Posts			\$1098.50

One mile equals 5,280 feet

## APPENDIX B

### ***A STRONGER BRACE*** ***It's Less Expensive & Easier To Build, Too!***

The following is a brace design that is less expensive and a bit easier to build. It's called a *Diagonal Strainer*. This design has been tested and compared to a standard "H" brace on clay soils. The diagonal strainer was 8% stronger than the "H" brace. The brace failed at a load of 8400 pounds (that's over 5 times the load you'd be likely to use on a 7 wire high tensile fence).

To build this brace you'll need the following materials and tools:

#### ***MATERIALS***

- 2 - 8 foot high quality pressure treated posts
- 1 - 4" x 3/8" brace pin
- 1 - twitch stick or (1) in-line strainer
- 20 feet of 12-1/2 gage high tensile steel fence wire
- 1-rock (the rock should have a flat side at least 6" x 8")

#### ***TOOLS***

- Post hole digger & rammer
- 3/8" drill (or a chisel)
- Hammer
- Chain saw

#### ***Here's how you build it***

1. Dig a post hole 4 feet deep (for every 6 inches you set a post beyond 3 feet you double the strength of the post). Place the post against the side of the hole closest to the source of stress. Make sure that this side of the hole is straight so that the post fits flush against it. This will provide a solid surface to pull against and leaves only 3 sides of the hole to pack.
2. Once the post is set, drill a 3/8" hole, 2 inches deep, 4 inches from the top of the post. The hole should face the direction of strain on the fence. If your post hole is less than 4 feet deep you'll either need a longer stay-bar or have to drill the hole lower on the post. The stay-bar should be at least twice as long as the height of the hole drilled in the post.

#### **Diagonal Strainer**

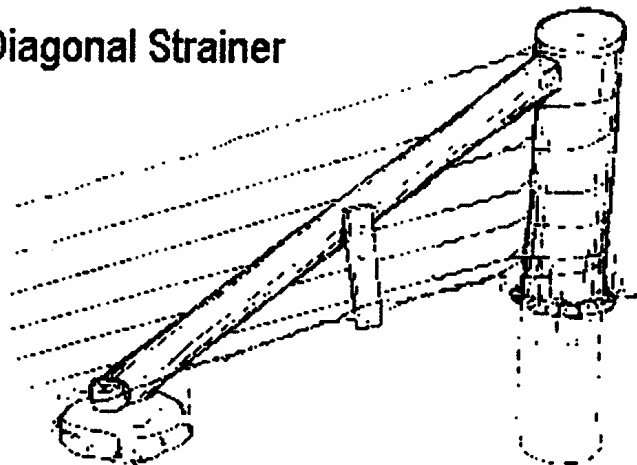

Note: A mortise was used instead of a brace pin on the brace in this illustration

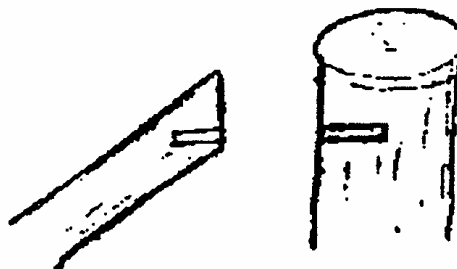

**3/8" holes 2" deep in post and stay**



3. Saw the end of the stay-bar so that it fits flush against the post. Drill a 3/8" hole, 2" deep in the end of the stay-bar.
4. Hammer the brace pin into the hole in the post. Slide the stay-bar on to the exposed pin. (As an alternative to brace pins, you can saw the stay-bar so that it fits into a 1/2" deep mortise chiseled into the post. This would replace steps 2-4.)
5. Find a rock or other solid object with a flat surface and place it on the soil surface under the end of the stay-bar in the direction of strain. Do not bury it.
6. Cut the bottom of the stay- bar so that it fits flush on the rock.
7. Take a half-round wood scrap and place it at the end of the stay-bar on the rock.
8. Loop the high tensile wire around the base of the post and around the end of the stay-bar on the rock. Fasten the wire to itself using a figure "8" knot or nicopress sleeves.
9. Insert the twitch stick and make several wraps in the wire until the wire is tight. An in-line strainer can be used instead of a twitch stick.

The force on this post is transferred through the stay-bar to the ground. It looks weird but it makes a solid brace.

## ***APPENDIX C***

# ***20 COMMON MISTAKES TO AVOID WHEN BUILDING A GOOD ELECTRIC FENCE***

***Wayne Burleson, Range Management Consultant  
Absarokee, Montana  
Rutbuster1@mcn.net***

### ***1. POOR EARTH GROUNDING***

Lots of folks still think you can skimp when it comes to adequate earth grounding. What we must all learn to do, is install several ground rods -at least three that are 6 to 8 feet long, galvanized, and attached with good ground clamps. The electricity must complete a full circle back to the charger through the ground. Poor grounding gives weak shocks. Think of the ground rods as radio antennas -the more reception, the better the shock.

### ***2. USING DIFFERENT TYPES OF METALS***

Don't do it. When you hook up steel wire to copper, something called electrolysis happens and the metal becomes corroded, making a poor contact and weakening shocking power.

### ***3. INADEQUATE ANIMAL TRAINING***

Each and every animal must learn that the fence hurts, so please build a handy training fence, preferably on heavy wet soil. Flag the fence for visibility, and entice the animal to test the fence.

### ***4. FENCEPOSTS TOO CLOSE TOGETHER***

(Note: this is for interior cross fences). Well-intended government agencies recommend lots of fenceposts in their fencing specifications. Fifty-foot spacing on flat land is just too close. You want the fence to act like a rubber band. When something runs into the wire, you don't want to break all the insulators or knock posts out of the ground. If the posts are spread apart far enough -say 80 to 100 feet -the wire will just bend to the ground and pop back up.

### ***5. TOO MANY WIRE TIE-OFFS***

Again, fencing specifications may call for braces every quarter mile wire (1,320') to tie the wire off. However, even 5,280 feet is OK, and actually adds more elasticity in the fence wire. This reduces the chance of wires breaking.

### ***6. WIRES TIED TIGHT TO EACH FENCEPOST***

The wires must float (move) past each line fence post. This is needed to maintain elasticity (that rubber band effect).

## **7. BUILDING NEW FENCES NEAR OLD EXISTING FENCES**

Old fence wires seem to be always moving somewhere and coming in contact with the new electrified wires. This almost always causes a complete short in the fence, and away the animals go.

## **8. BOTTOM WIRE IN CONTACT WITH HEAVY, WET VEGETATION**

Wet grass will suck lots of juice out of any fence charger. Hook up the lower wires separate from the other wires, and install a switch for the lower wires that you can turn them off when the grass is tall. Brush is another problem – buy a BIG charger. When you check a smooth wire fence, drive your vehicle so the wheels will drive over the vegetation and knock some of it down. Four-wheelers work great for this. Don't spray under the wire. You will end up with some weeds growing there.

## **9. POOR QUALITY INSULATORS**

Be careful here. Sunlight deteriorates plastic. Buy high quality, long lasting insulators. Usually black ones are treated to resist degradation by ultraviolet light. Poor quality insulators may turn white or clear after a few years in direct sunlight and shatter like glass.

## **10. STAPLES DRIVEN IN ALL THE WAY**

When using plastic tubing as an insulator, don't staple it too tightly. A staple may damage the tubing next to a ground wire, causing a hidden short.

## **11. SOLAR PANELS NOT DIRECTLY FACING THE SUN**

This seems almost too obvious to be a problem, but a solar panel won't function at its potential if not properly installed. Please read the instructions.

## **12. DON'T ELECTRIFY BARBED WIRE**

An animal can get caught up in the barbs, and the shock from a big charger could kill the animal.

## **13. KINKS IN HIGH-TENSILE WIRE**

A small kink in stiff wire will always break. Also avoid hitting this kind of wire with a hammer, as this will easily damage the wire, causing a break. Always cut out a damaged section of high tensile wire and splice it. A hand-tied "square knot" makes the strongest splice.

## **14. INSTALLING IN-LINE STRAINERS CLOSE TOGETHER**

Wires will flip together once in awhile. If in-line strainers (wrench-like gadget to keep the wire tight) are installed one above the other, they will sometimes hook up. Separate in-line strainers by a fencepost and they will never catch on each other.

### ***15. WIRES TOO CLOSE TO EACH OTHER***

Keep them at least 5 inches apart. When you and a partner are building fence, make a 5" mark in ink on your pants the height of the wire - saves time. Use 31" top wire for cows.

### ***16. WIRE STRETCHED TOO TIGHT***

Use inline-strainers that pull just enough to get the sag out of the wire between the fenceposts.

### ***17. NO VOLTMETER***

Without a voltage meter to check how hot a fence is, you're just guessing. Livestock will find a low voltage fence is a joke and walk right through it.

### ***18. WIRE TOO SMALL***

The larger the wire, the more electricity it will carry. Don't skimp here, especially if you are going long distances. 12.5 gauge wire is good for over 20 miles of hot fence.

### ***19. INADEQUATE CHARGER***

A wimpy fence charger gives you a wimpy fence. Don't skimp here because this is where most fences fail. Build a strong fence and hook it up to a great big fence charger.

### ***20. TOO BUSY TO CHECK THE FENCE***

Yes, these fences are much easier to build and fix. However, without routine checking, they tend to slip and lose effectiveness. Once the animals become untrained, it takes an extra effort to retrain them. Solution: carry a small repair kit with you at all times, install switches away from the charger, turn the fence off and make the necessary repairs as routine as moving the mineral mix.

## APPENDIX D

### Fencing Vendors

It is suggested that you contact several of the companies and request materials. Most suppliers have "how to" information covering layout & design and cost estimates.

#### Regional:

Agway, Inc.  
PO Box 115  
Detroit, ME 04929

Blue Seal  
PO Box 990  
Augusta, ME 04330  
800-734-1945  
<http://www.bluseal.com>

Gallagher Fence  
Brant Miller  
67 Post Rd.  
Bowdinhams, ME 04008  
Phone: 207-666-3270  
Pager: 821-1303  
e-mail: [bsmiller@gwi.net](mailto:bsmiller@gwi.net)

Katahdin View Farm & Fence  
George Miller Jr.  
Hampden, ME  
Phone: 207-862-4030

Paris Farmers Union  
16 Skillings Ave.  
South Paris, ME  
Phone: 207-743-1616  
Fax: 207-743-8564  
[www.parisfarmersunion.net](http://www.parisfarmersunion.net)

Wellscroft Farm Fence  
Systems  
167 Sunset Hill-Chesham  
Harrisville, NH 03450  
Phone: 603-827-3464  
Fax: 603-827-2999

#### United States:

Zareba Systems  
Technical Support &  
Manufacturing  
2411 Seventh Street NW  
Rochester, MN 55901

phone: 507-288-7777  
fax: 507-252-3700  
[www.zarebasystems.com](http://www.zarebasystems.com)

Circle J. Sheep Equipment  
29743 Hwy 63  
Bloomfield, Iowa 52537  
Phone: 641-929-3388  
email: [bacjones@netins.net](mailto:bacjones@netins.net)  
[www.case-agworld.com/  
c.Aw.circleJ.home.html](http://www.case-agworld.com/c.Aw.circleJ.home.html)

John Gingras, Consultant  
Compass Grazing Systems  
4626 S. Center Hwy  
Suttons Bay, MI 49682  
phone: 800-968-1778  
e-mail: [gingrasj@pilot.msu.edu](mailto:gingrasj@pilot.msu.edu)

Dare Products, Inc.  
860 Betterly Road  
Battle Creek MI 49015  
phone: 616-965-2307 or  
800-922-3273  
fax: 616-965-3261  
e-mail:  
[brad@dareproducts.com](mailto:brad@dareproducts.com)  
[www.dareproducts.com](http://www.dareproducts.com)

Deutschlander Fencing  
Rt. #4 Box 43  
Pine City, MN 55063  
phone: 320-629-2744  
fax: 320-629-3875  
[www.geocities.com/SouthBeach/  
Keys/4212](http://www.geocities.com/SouthBeach/Keys/4212)

Fi-Shock, Inc.  
5360 National Drive  
Knoxville, TN 37914  
phone: 865-524-7380 or  
800-251-9288  
(U.S. and Canada)  
fax: 865-673-4770  
e-mail: [info@fishock.com](mailto:info@fishock.com)  
[www.fishock.com/](http://www.fishock.com/)

Gallagher Power Fence  
Systems  
P.O. Box 708900  
San Antonio, Texas 78270  
Phone: 800-531-5908 or  
210-494-5211  
Fax: 210-494-9364  
e-mail:  
[info@gallagherusa.com](mailto:info@gallagherusa.com)  
<http://222.gallagherusa.com>

Geotek-Common Sense Fence  
Geotek, Inc.  
1421 2<sup>nd</sup> Avenue NW  
Stewartville, MN 55976  
phone: 507-533-6076 or  
800-533-1680  
fax: 507-533-4784  
e-mail:  
[geosales@geotekinc.com](mailto:geosales@geotekinc.com)  
[www.geotekinc.com/fence/index.  
html](http://www.geotekinc.com/fence/index.html)

Kellogg's Seed Service  
3367 Neal Road  
Paradise, CA 95969  
phone: 530-872-2624  
fax: 530-877-0256  
e-mail: [wlk42@co.com](mailto:wlk42@co.com)  
[www.kelloggseedservice.com](http://www.kelloggseedservice.com)

Kencove Farm Fence, Inc.  
344 Kendall Lane  
Blairsville, PA 15717-8707  
phone: 724-459-8991 or  
800-536-2683  
fax: 724-459-9148  
e-mail: [ck@kencove.com](mailto:ck@kencove.com)  
[www.kencove.com](http://www.kencove.com)

Kentucky Graziers Supply  
1929 Main Street  
Paris, Kentucky 40361-1110  
phone: 859-987-0215 or  
800-729-0592  
fax: 859-987-6461  
email: [info@kygraziers.com](mailto:info@kygraziers.com)  
[www.kygraziers.com](http://www.kygraziers.com)

Kiwi Fence Systems  
121 Kiwi Road  
Waynesburg, PA 15370-8070  
phone: 724-627-8158  
fax: 724-627-9791  
e-mail:  
[KiwiInfo@kiwifence.com](mailto:KiwiInfo@kiwifence.com)  
[www.kiwifence.com/](http://www.kiwifence.com/)

Max-Flex Fence Systems  
U.S. Route 219  
Lindside, WV 24951  
phone: 800-356-5458  
fax: 304-753-4827  
e-mail: [mail@maxflex.com](mailto:mail@maxflex.com)  
[www.maxflex.com/](http://www.maxflex.com/)

North Central Plastics, Inc.  
(A Zareba Company)  
906 Fifth Avenue East  
Ellendale, MN 56026  
phone: 507-684-3721  
fax: 507-684-3722  
e-mail: [ncp@redsnapr.com](mailto:ncp@redsnapr.com)  
[www.redsnapr.com](http://www.redsnapr.com)

Parker McCrory  
Manufacturing Co.  
2000 Forest Ave  
Kansas City, MO 64108  
phone: 816-221-2000  
fax: 816-221-9879  
e-mail: [info@parmakusa.com](mailto:info@parmakusa.com)  
[www.parmakusa.com](http://www.parmakusa.com)

Premier Fence System  
2031 300th  
Washington, Iowa 52323  
phone: 800-282-6631

Southwest Power Fence  
26321 Hwy 281 North  
San Antonio, TX 78260  
phone: 830-438-4600 or  
800-221-0178  
fax: 830-438-4604  
[www.swpowerfence.com/](http://www.swpowerfence.com/)

Valley Oaks Ranch Supply  
40,000 Bear Creek Road  
Springville CA 93265  
phone: 559-784-3697 or  
800-477-6908  
e-mail: [jared@2xtreme.net](mailto:jared@2xtreme.net)  
[www.vosupply.com/](http://www.vosupply.com/)

Waterford Corporation  
404 North Link Lane  
Fort Collins, CO 80524  
phone 800-525-4952  
e-mail: [watrford@frii.com](mailto:watrford@frii.com)  
[www.waterfordcorp.com](http://www.waterfordcorp.com)

Wedge-Loc Co. Inc.  
1580 N. Pendleton Drive  
Rio Rico, AZ 85648  
phone: 800-669-7218  
e-mail: [sales@wedgeloc.com](mailto:sales@wedgeloc.com)  
[www.wedgeloc.com/](http://www.wedgeloc.com/)

#### **Canadian:**

Baygard (purchased by Parker  
McCrory)  
Parker McCrory  
Manufacturing Co.  
2000 Forest Ave  
Kansas City, MO 64108  
phone: 816-221-2000  
fax: 816-221-9879  
e-mail: [info@parmakusa.com](mailto:info@parmakusa.com)  
[www.baygard.com/indexmain.html](http://www.baygard.com/indexmain.html)

Hallman Fence Systems  
4 Terracon Place  
Winnipeg MB

R2J 4G7 Canada  
phone 204-223-7777  
fax: 204-233-2998  
e-mail: [info@hallman.ca](mailto:info@hallman.ca)  
[www.hallman.mb.ca](http://www.hallman.mb.ca)

Phoenix Agritech (CA) Ltd.  
P.O. Box 10  
Truro, Nova Scotia  
B2N 5B6  
Canada  
phone: 902-662-2444  
fax: 902-662-2888  
e-mail: [phoenix@fox.nstn.ca](mailto:phoenix@fox.nstn.ca)  
<http://fox.nstn.ca/~phoenix/phoenix.html>

Stinger Products\*  
2430-80 Ave.  
Edmonton, Alberta  
T6P 1N2  
phone: 780-463-6133 or  
800-661-3617  
fax: 780-469-4317  
[www.stinger.okko.com](http://www.stinger.okko.com)

#### **Worldwide:**

AEC Electric Fencing Limited  
Hotline Works  
Brunel Road  
Newton Abbot, Devon,  
TQI 24PB, England  
phone: 01626331188  
fax: 0800 873 7893  
e-mail: [sales@hotline-fencing.co.uk](mailto:sales@hotline-fencing.co.uk)  
[www.hotline-fencing.co.uk](http://www.hotline-fencing.co.uk)

PEL Industries Ltd  
P.O. Box 51-093  
Auckland, New Zealand  
phone: +64 9 274 5726  
fax: +64 9 274 6199  
e-mail: [info@pel.co.nz](mailto:info@pel.co.nz)  
[www.pel.co.nz](http://www.pel.co.nz)

## ***APPENDIX E***

### **FARM FENCES – PLANNING, CONSTRUCTION, AND COST**

**Ken Andries, Ph.D.**

**Livestock Specialist**

**University of Maine Cooperative Extension**

#### **Introduction**

Fences have been used for livestock control for many centuries. Control of movement of domestic and wild animals has been their primary purpose. The location, type of animal, and its habits determine what type of fence works best.

The original fences were hedgerows or rock. Today we have many fencing options available to fit our specific situation. Materials range from vinyl to metal and wood. Wire can come in many forms including barbed, smooth, net and even chain-link.

Regardless of materials, construction of the fence determines how long and how well the fence will do its job. Proper construction evolves planning as well as material selection and the actual building of the fence.

#### **Planning Process**

We must start with a good plan to build a good fence. This is true whether building a permeable or temporary fence. Good planning includes making a map of the area, laying out the desired fence locations, and material selection.

The planning process starts by deciding where the fence will go, this means preparing a map of the area.

You will need information from three resources for the map: 1) soil type map, 2) aerial photograph, and 3) a topographical (topo) map of the location. Land capability or soil type maps show what soil types are in an area and what use and management practices are best for the land. Aerial photos show details of the present farm layout and give you an overall perspective of the land. Topo maps tell you the “lay of the land” or elevations and contours of your farm. These three pieces of information should be available from your local farm service agency (FSA) or Natural Resources Conservation Service (NRCS).

The information is extremely important if you are working with a new place. However, it is just as useful on property you have owned or farmed for years.

Once you have the information, map out boundaries of hay, crop, pasture, and all other use areas for the property. This defines the boundaries you will be working with. Use the soil and topo maps to avoid problem areas such as wet locations as much as possible. Fence out ponds and low wetland areas that hold water on regular bases to improve herd health and maintain a clean water supply for the animals.

You should review the plan and if possible view the location of the new fences. Where drainage ditches or ponds added since the last aerial photo, do you need to clear a lane through a wood lot, are old fences present that were not on the map or photo? These are all things that you will need to adjust for in your plan.

With the map complete, you should be ready to determine the size of your pasture. Plot the new fences and plan for gate locations, allies/lanes, and other features you will need to move and work cattle. Then measure the length and plan for corner post, gate post, and in line bracing or pull post. This will allow you to make an accurate list of material you will need for the project.

Lanes are very useful in moving livestock from one pasture to another or for moving to a central working facility. Gates should be located in corners for ease of moving livestock and across from each other along lanes.

### **Types of Fences**

There are two basic types of fences, permanent and temporary. Permanent fences are designed and constructed to last a long time, generally 20 to 40 years, while temporary fences are used for a short time, usually a few months. The material and construction methods differ with each type. Permanent fences are made with sturdier post and constructed to provide long service with minimal maintenance. Temporary fences are generally used for rotational or seasonal grazing, to keep livestock away from hay stacked or cut in a pasture, or to provide a “quick fix” for a permanent fence to be repaired later.

Permanent fences are used around the perimeter of your property as well as major dividing fences or cross fences in pastures. They are constructed with mettle and/or wood post in general and define the basic shape of your pasture.

Temporary fences are not as well constructed and generally have fewer strands of wire, greater distance between post, and generally will only last 3 months to a year. They are used in intensive grazing operations, to separate animals from hay or winter forage. Or to reestablish parts of a pasture. They can also be used to provide a “quick fix” for downed permanent fences to be repaired later.

In the planning stage you will need to plan for both types of fences as they fit your operation. All perimeter fences need to build as permanent fences. Also any cross fences should be permanent as well as those around ponds. Temporary fences can be added at a later date and or moved as needed. However if you plan to use temporary fences a sturdy post in key locations along the permanent fence can be very helpful. Also the type of permanent fence may be selected to aid in adding the temporary fences later.

### **Material Selection**

Now that the fence is planned and you have the measurements, its time to select the materials. Fencing materials commonly used include boards, barbed wire, woven wire, cable, mesh wire and high tensile wire. Electricity can be added to most fence types to increase effectiveness. Post materials include wood, metal, plastic, fiberglass, and composite materials. The purpose of the fence will determine the most appropriate material for your situation.



## Fencing materials

Board and chain link fences are very nice and if maintained properly they will work for many years. However, their cost makes them impractical for most operations. These materials would be good choices however, for around farm buildings, yards, or gardens. They can improve or enhance the appearance of a home or farm yard.

Cable or pipe is another good fence material for specific applications. These materials work very well when used for holding pens or dry lot operations. Cable and pipe are both very strong fences. Cables allow for some give to the fence while pipe is very ridged. Again the cost of these types of fences are prohibitive for most applications.

Barbed wire is probably the most common type of wire used today. The typical barbed wire fence will have 3 to 6 strands of wire and is used for cattle, horse or large exotics. This type of fence is not well suited for control of smaller animals or for wildlife control. Barbed wire is generally sold in roles of 80 rods (80 rods = 1320 ft. = 1/4 mile) in length and is available in several styles and sizes. A standard barbed wire fence has 5 to 6 post per 100 ft and may have wire stays between the post.

High-tensile fences are growing in popularity and can be used in place of barbed wire. These fences are made of smooth wire and generally have 5 to 10 strands. The wire is stretched between pull post with tension being maintained by springs in the fence. There are also ratch devices placed in the run to allow you to adjust tension if needed. The advantages are that it is somewhat easier to handle, easier on livestock, and easy to adapt. It is also generally more economical than other fences and has a longer life expectancy. High tensile fences work well for large livestock and can be adapted better than barbed wire

Woven or net wire, also known as hog wire, fences are the last type we will discuss. These fences are best suited for small animals such as sheep, goats, or hogs. It is also the best for controlling some types of wildlife. The wire is a series of horizontal wires held apart by vertical stays. The square or rectangle gaps in the wire generally get smaller towards the bottom of the fence. The wire generally comes in 26 to 48 inch heights. This wire is generally more expensive than barbed wire fence. In many applications a single strand of barbed wire is placed above the net wire to help keep animals from jumping or to keep large animals from reaching over the top. A barbed wire at the bottom of the fence will do the same to discourage going under the net wire.

## Electric fencing

Electric fences are becoming more popular due their effectiveness and ease of making quality temporary fences. Electricity can be added to any fence with a little modification. Electric fences are very effective because they provide a physical and physiological barrier.

Electric fences can be temporary or permanent. Permanent electric fences generally utilize high tensile fencing materials and are either a fence themselves or a single wire added to an existing permanent fence. Temporary electric fences can then be made as extensions off the permanent fence.

The addition of insulator is all it generally takes to make the conversion from a regular to an electric fence. Offset stays are used to add an electric wire to existing conventional fences. In a new application in high tensile fences, every other wire or each wire can be “hot”.

To make an electric fence effective you need a good fence charger. The setup of the charger is also important. A charger that is not well grounded will not be effective. You also need to follow recommendations for lightning protection provided by the manufacture. Poor instillation or lack of maintenance can make electric fences very dangerous. Home made chargers and improper instillation can result in serous injury or death.

The fence needs to be grounded to work. Most permanent fence application have every other wire hot. The other wire acts as a ground. In single wire applications the moisture in the ground allows for completion of the circuit and improves effectiveness of the fence.

When selecting a charger, be sure to consider current and future plans. Chargers are designed for a specific length of fence. If you exceed that length you reduce the effectiveness of the fence and in some cases can render the fence useless. Additions of cut-off switches and spring gaps also improve your ability to work on a fence if problems occur. Again planning is important to decide the best strategies for your situation.

### **Post Selection**

Fence post are a very fundamental part of a fence and proper selection and installation will determine the life of the fence. There are three basic materials used for post: wood, mettle, and fiberglass. Plastic and some other recycled or composite materials are also being used but are not common in most areas.

When selecting post materials, we need to look at ease of installation, longevity, and availability. The type of the fence, permanent or temporary will also play a role.

Corner post, gatepost and all pull post/brace assembly need to be very sturdy to hold the tension in the wire and/or weight of a gate. You should have a brace assembly or corner post with brace every 650 feet or less along a fence to insure good tension on the wire. Wooden post for these uses should have a top diameter of 8 inches. Mettle post should be 3 to 4 inches minimum with a concrete anchor 20 sq. inches and 3 ½ feet deep to insure it holds.

Line post should be placed every 12 to 20 feet for wooden post over 3 ½ inches in diameter or 12 to 15 feet for mettle T- post or wooden post under 3 ½ inches in top diameter.

Fiberglass post can be used in the place of mettle or wooden post on the 15 or less spacing. These post give some flexibility and are very useful for electric fences. Composite and recycle material post can be use similar to wood or t - post depending on their size and manufacture’s recommendations.

When selecting wooden post consider the type of wood as well as wood treatment. Treatment can double or even triple the live expectance of a wooden post. Black locust and cedar make

very good post. Many other hard woods also have a long life expectancy if pressure treated. Softer woods are more subject to rot as is hickory and red oaks.

Mettle post have replaced wood post in most areas due to their ease of handling. Mettle post are driven in to the ground and wire is attached by clips. Small wood post can also be driven but larger ones require digging post holes for proper placement.

Composite and plastic post can be used in place of other types depending on material and construction. These materials are generally used for temporary fences and electric fences.

A final note about fence post. A living tree should never be used as a fence post. As the tree grows the wire becomes imbedded in the wood. This causes pressure on the wire and increases the degeneration rate of the wire. This combines to increase wire breakage. It also decreases the future value of the timer. If necessary cut trees along the planed fence line and kill the stumps. Keep trees and other weeds from growing up around the fence to increase its useful life.

## **Fence Construction**

### Corner and Brace assembly

One of the major challenges in fence construction is keeping the wire taught over the years. This is the job of the brace and corner assemblies. These groups of post are must be designed to take the pressure and strain of keeping the wire tight and holding gates over the years without moving. Proper construction and placement will increase the life of the fence while reducing maintenance.

Corner post and brace post assemblies consist of two to three large diameter post (top diameter 8 in or grater) and need to be supported with a cross post and tied together with a diagonal wire loop. This loop should go from the top of the post in the direction the pull is coming from and the bottom of the support post (middle in a three post design). This allows the post to transfer the force being placed at on its top to the ground level of the support post anchoring it in place. See the figures for more information on design and placement of brace assemblies.

Figure 1. Double span brace post assembly. Post depths shown are considered to be minimum.

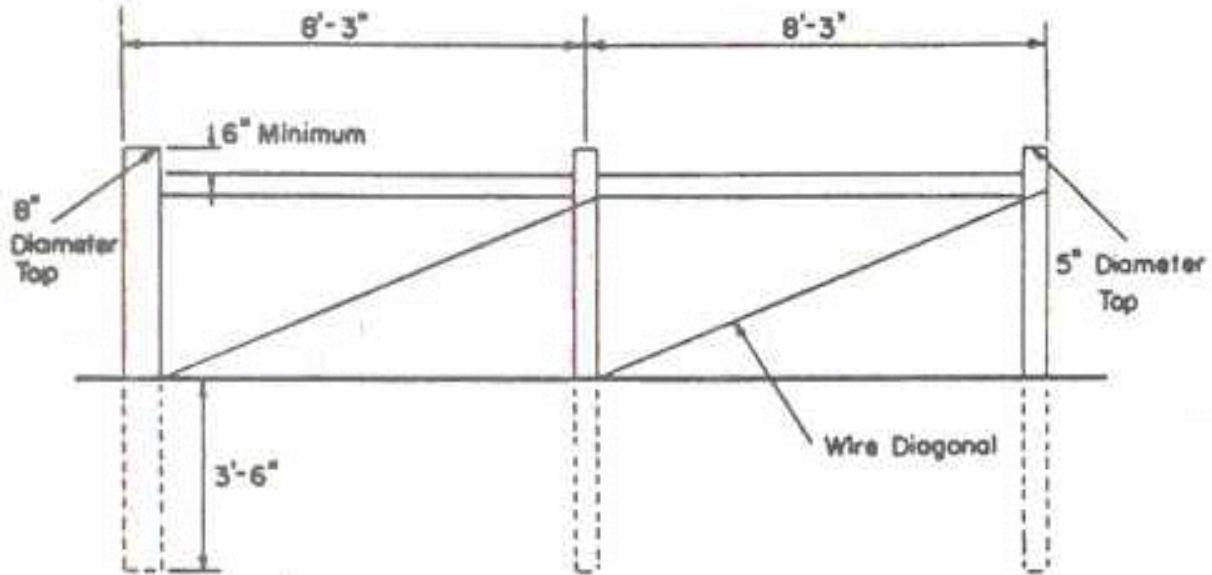
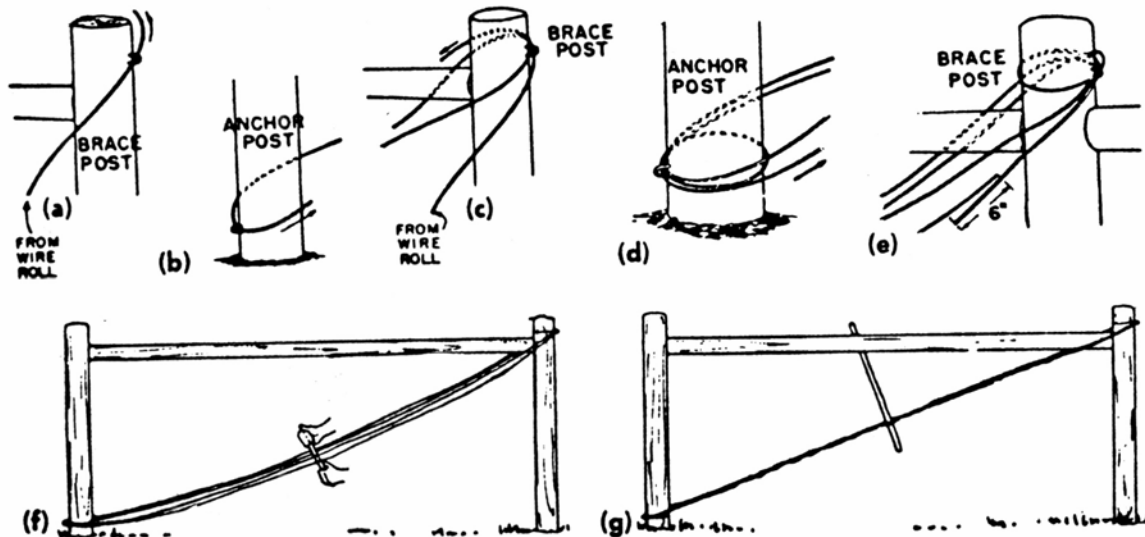

Figure 2. Correct procedure for threading the wire used as diagonal in the brace assembly



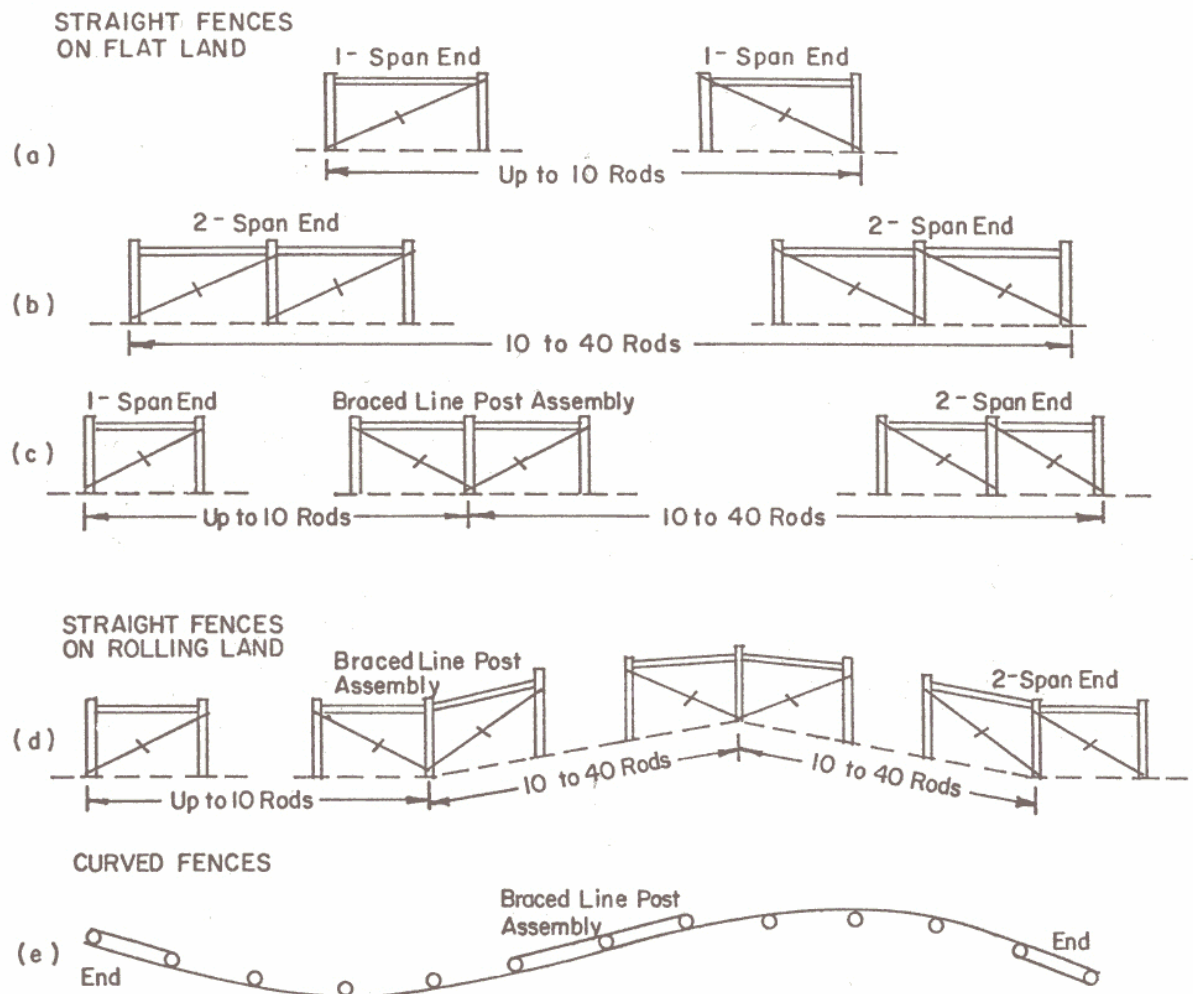

Figure 3. A. Types of anchor and brace assemblies and where to locate them. (a) for fence lengths of 10 rods or less, use single span end construction. (b) for fence lengths of 10 to 40 rods, use double span end construction. (c) for fences more than 40 rods long, use a brace line post assembly to divide the fence lengths. (d) on rolling land, fence stretching is easier if braced line-post assemblies are located at the foot and top of each hill. (e) Contour fences, more than 20 rods long should have a braced line post assembly installed to keep the stretches to 20 rods or less. Install in straight section at least one post span away from a curve. Don't install on a curve. It won't hold well.

## **Conclusions**

Proper fence construction will result in many advantages. The fences will last longer and be more effective if planned and constructed properly. There are many products available for use in fence construction. This makes the planning process more important because they are not all effective for all types of animals and in all situations.

The building process should always start with a plan. The plan needs to include current and predicted future needs. Take into consideration the lay of the land and current boundaries. Be sure to clear a path for the fence through woods and thickets. This will help in building a strong fence and increase its life.

Electric fences are very good for keeping livestock confined. They can also increase the life of existing fences. However, be careful and select only quality products and have them tested regularly to be sure they are safe.

Finally, remember that a well constructed fence is no guarantee that livestock will not get out. Proper maintenance and checking for problems is very important to reduce your chances of liability. To our knowledge there is not uniform law related to fences in Louisiana as to what makes a legal fence. The better the fence is constructed and the better maintained the better for you. Parameter fences are the major concern in these types of situations. For cattle they should be five strands of barbed wire or net wire. Electric fences are also helpful but pose their own problems. Check with the local district attorney's office for information on local regulations related to fences and livestock confinement.

### Literature Cited

Kay, Furman W. Fences for the Farm. University of Georgia Cooperative Extension Service Circular 774, 1985.

Turner, L.W., C.W. Absher, and J.K. Evans. Planning Fencing Systems for Intensive Grazing Management. University of Kentucky, Cooperative Extension Service ID-74, 1986.

Watson, Harold. Electric Fences. Southern Regional Beef Cow-Calf Handbook. SR7002, 1977

Watson, Harold. Wire Fences. Southern Regional Beef Cow-Calf Handbook SR7004, 1978

*Notes*

## Lesson 3 Quiz

## Fencing Systems

1. Before setting the first post, what non-fence issue should livestock producers think about?
2. Give three reasons why livestock operators should consider high tensile electric fence:
3. The effectiveness of any electric fence depends on:
4. The ability of a fence to deliver a shock depends on three things:
5. When buying an energizer, what are two things you should not do:
6. \_\_\_\_\_ is the leading cause of electric fence problems.
7. A minimum of \_\_\_\_\_ ground rods should be used for each energizer.
8. If electric fences are to consistently hold livestock, \_\_\_\_\_ is essential.
9. When using high tensile wire, a \_\_\_\_\_ must be used and make sure you start at the \_\_\_\_\_ end.
10. Temporary electric fences give livestock producers a powerful tool for \_\_\_\_\_.
11. A \_\_\_\_\_ is essential for rolling up polywire or polytape. Rolling up the polywire or polytape back onto the spool, on a stick or around your arm, simply \_\_\_\_\_



12. What are some advantages and disadvantages of:

a) Metal "T" posts

Advantages

Disadvantages

b) Fiberglass Rods

Advantages

Disadvantages

c) Tread-In Posts

Advantages

Disadvantages

*Please list any questions you may have that weren't answered in this lesson:*

\*\*\*\*\*

Name \_\_\_\_\_ Phone \_\_\_\_\_

Address: \_\_\_\_\_

(Optional) Fax: \_\_\_\_\_ E-mail: \_\_\_\_\_